

DOSSIER DE POSE

ALU  EUROPE

FENÊTRES POUR LA VIE

| **CPS** |

(Minimalist sliding system with thermal break)  
(Système coulissant minimaliste avec rupture thermique)



CHECK LIST - PRODUÇÃO DE JANELAS NA SÉRIE EXPANSION:

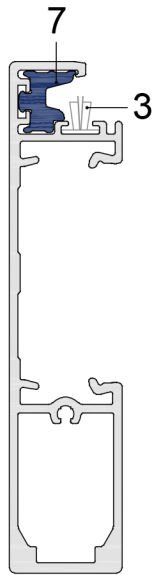
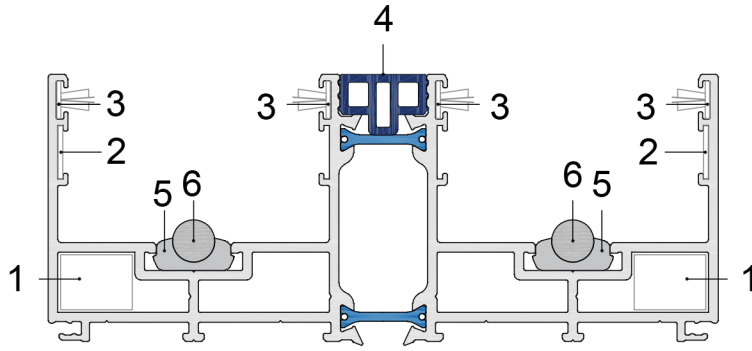

1

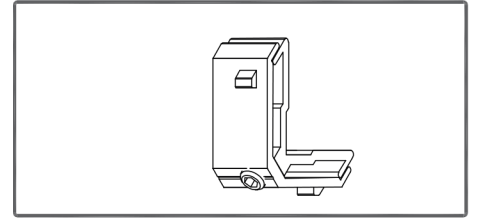

FE 15

2

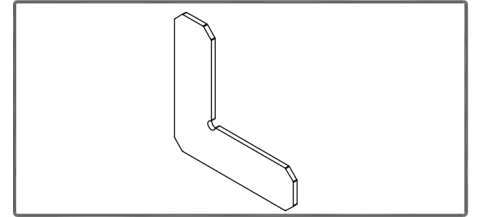

FE 16

3

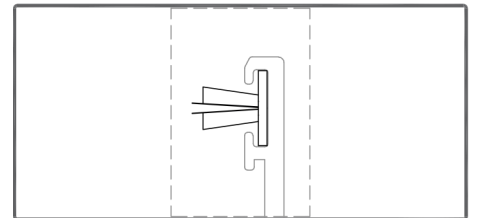

7x5,5 Q-Fin

4

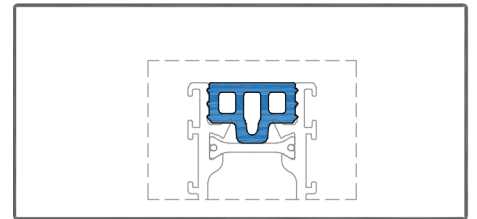

J 2701

5

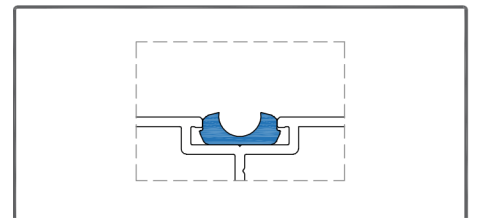

J 2711

6

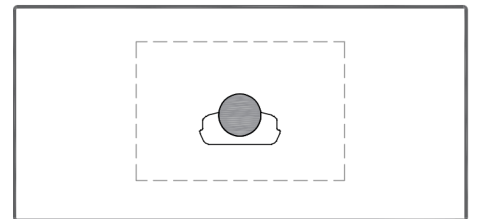

EXP 100

7

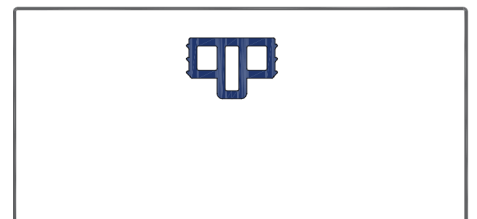

J 2701



**CHECK LIST - INSTALLATION OF WINDOWS IN THE EXPANSION SERIES:**

INDICATIONS: Mark with one (X) the rectangles corresponding to the points verified and considered "WELL DONE" in each of the frames of said work.

**1. ASSEMBLY:**

- 1.1. Verification of the planimetry and leveling of masonry before the fixed hoops are applied (VERY IMPORTANT) .....
- 1.2. Fixation of fixed rings with correct fixing points (according to catalog) .....
- 1.3. Check the measurements and position of the glasses before they are applied.
- 1.4. Application of trolleys (verification of correct fit and alignment) .....
- 1.5. Superior anti-surveys applied .....
- 1.6. After the central and lateral moving profiles are clipped, check all clearances .....
- 1.7. Application of the lower and upper mounting bolts of the hoops .....

**SPECIAL CASES:**

- In vain tri-rail or tetra-rail, confirm the application of the rufos of water collection according to the instructions in catalog .....
- Go wider than 6m, you will need to patch the EXP-100 guide. Check if the splice is made undone between these 2 profiles .....
- Alert the customer to the cleaning care essential to the proper functioning of this system (see technical catalog pages) .....

**COMMENTS:**

## CARE FOR MAINTENANCE FOR EXP SYSTEMS

### 1. IN THE MANUFACTURE (CORRECT EXECUTION OF THE FRAMES):

All frames must be executed using our instructions and technical catalogs. If you find the data provided insufficient, consult the RCN Technical Department or request the presence of an RCN Technician.

#### IMPORTANT:

- When performing this system for the first time, you must request the presence of an RCN technician to technically assist in all phases of execution of at least 1 frame:
- Pay attention to the correct execution of water drainage;
- Pay attention to the application of the correct plush (Plush 7x5.5 Q-Fin);
- Pay attention to the application of the windbreaks in the fixed hoops;
- Machining the mobile profiles according to the plans of the catalog;
- Perform a correct application of all accessories;

### 2. AT THE ASSEMBLY (RIGOR IN THE PLANIMETRIAS OF THE WALLS):

For an excellent operation, it is extremely important the operator / installer of this system to sensitize and make responsible the designer and consequently the constructor for a high rigor in the plans and leveling of the masonry for the spans to which this System is destined.

They must check these same characteristics (Planimetry and Leveling) before applying the fixed hoops and only after confirming the correct conditions must be carried out the application in the work, always with the maximum rigor.

### 3. AFTER ASSEMBLY (CARE OF MAINTENANCE):

#### PROTECTION OF FRAMES DURING THE CONSTRUCTION PHASE:

Usually the assembly of the frames occurs at a stage where there are still works and finishings to be carried out in the building. This is normally the most critical and harmful period for already installed frames, especially for sliding areas (lower sills). It is essential to make the professionals of the work who use these spans as stalls to continually adopt all the necessary measures so that no type of garbage (sand, dust, paints, stones, etc ...) will interfere in the functioning of the system, or irreversibly damage. It is advisable to apply the appropriate protections so that the frames are safeguarded both to the entrances of rubbish and to possible shocks. It is strongly advisable to immobilize as many frames as possible and only activate after completion of all work on site.

#### LACED AND ANODIZED ALUMINUM

Aluminum after installation on site requires regular cleaning to keep its surface in good condition. No matter what the aluminum parts, profiles or accessories, if they are not properly treated they can suffer damages that, in certain situations can be irreparable.

#### CONTACT WITH OTHER MATERIALS

Whenever the material is hit by glues, mastics or similar products, cement, lime, paints or any other elements used in construction, it should be immediately removed using a liquid detergent of neutral PH diluted in water.

#### CLEANING OF SLIDING AREAS.

The areas where the trolleys slide should always be clean and free from any objects or materials (eg sand, stones, sawdust, dust, dirt, etc.) that could diminish the capacity of the trolleys or even damage them. These impurities can cause irreparable damage and consequently a worse functioning of the system.

Such cleaning must be carried out as often as necessary.

#### CLEANING PRODUCTS TO BE USED

Generally, a soft cloth soaked in water is sufficient to clean the aluminum. However, to facilitate the operation, a diluted soft liquid (5% by volume) neutral detergent of the Teepol type can be added.

#### CLEANING PRODUCTS TO AVOID

Never use brushes, scourers, scouring pads or any other type of abrasive material as well as solvent cleaners (eg thinner, clean ammonia glass, etc.).

#### CLEANING FREQUENCY

Cleaning must be carried out whenever the natural appearance of the finish begins to change or when there are notorious deposits of atmospheric or industrial pollution. However, the following rule can be established regarding the cleaning frequency:

- Maritime and / or industrial zones: 3 months;
- Rural areas: 6 months;
- Areas where strong salt deposition occurs: the cleaning frequency must be identified in order not to allow prolonged residence of the salts.

(Fixed frames: Masonry fixing bolt holes - 2 RAILS)

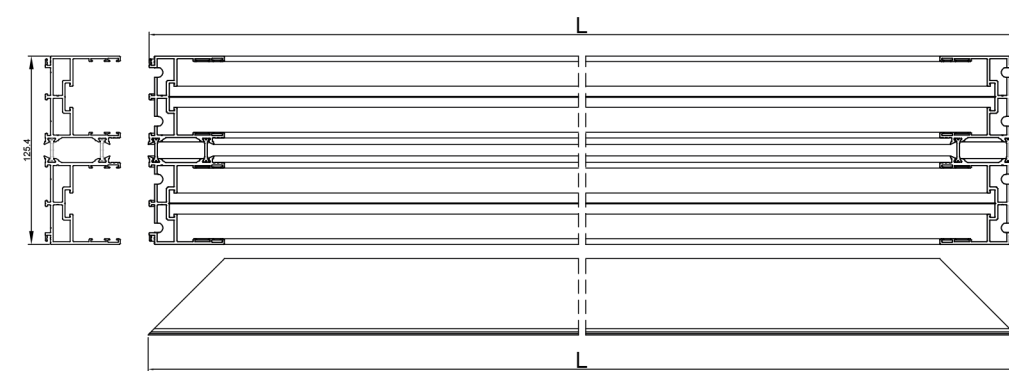
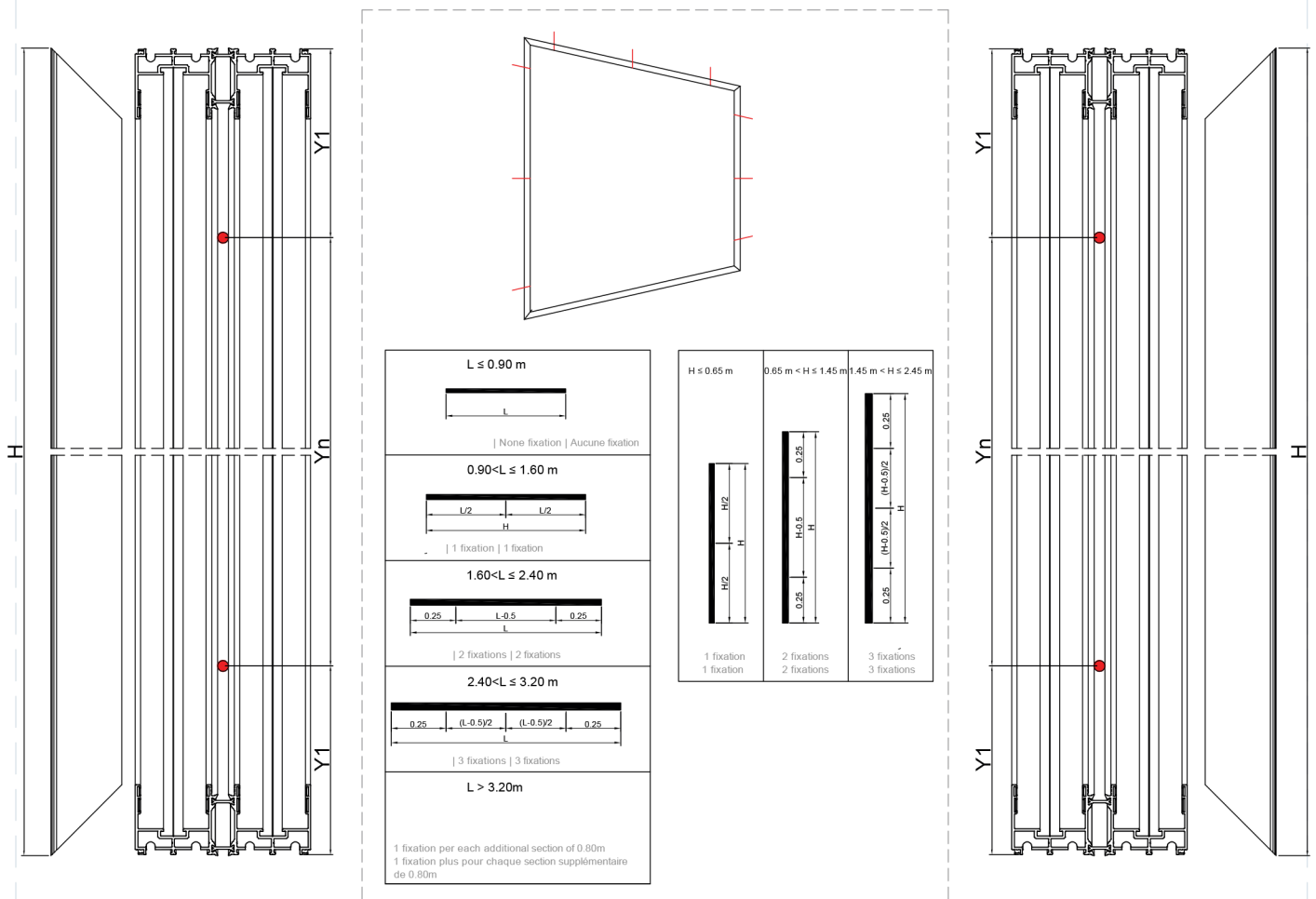
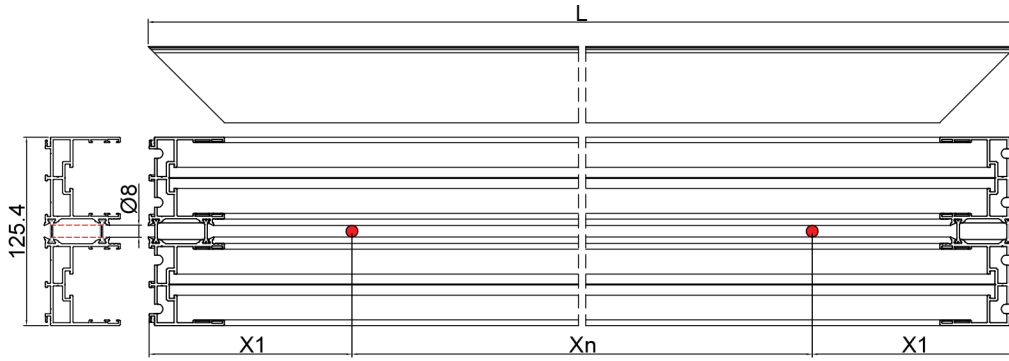

(Fixed frames: Masonry fixing bolt holes - 3 RAILS)

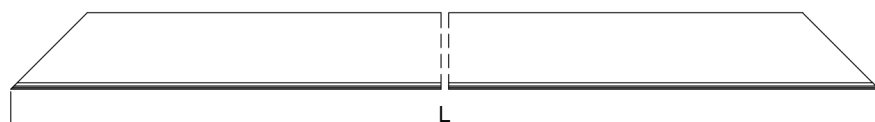
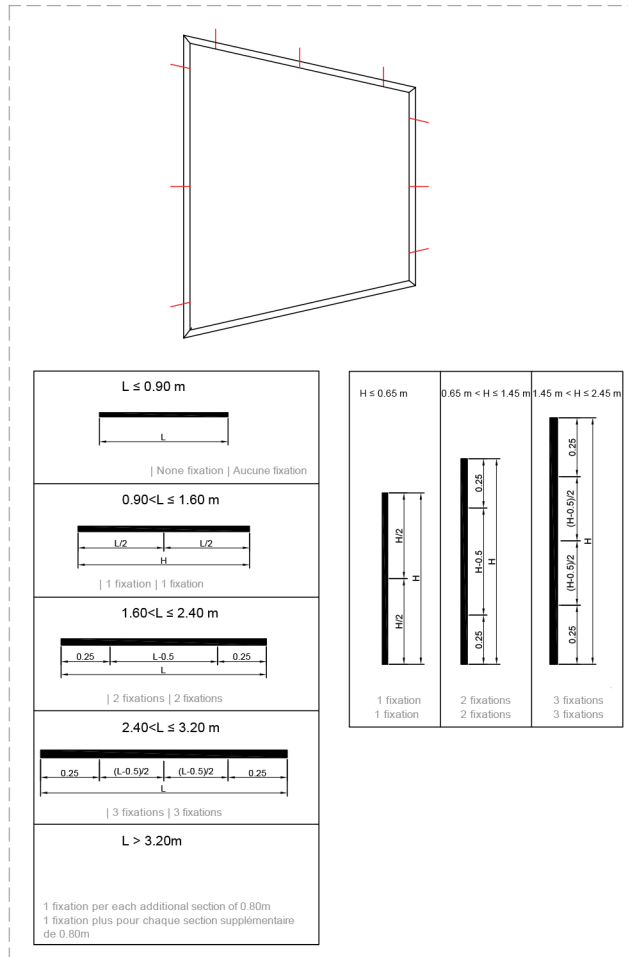
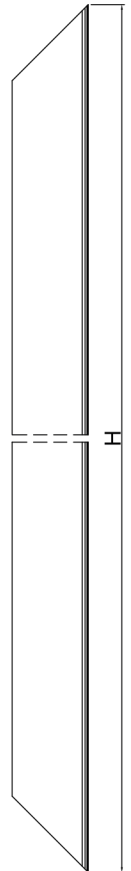
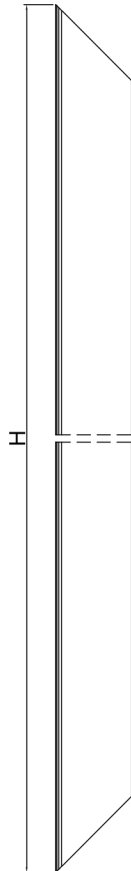
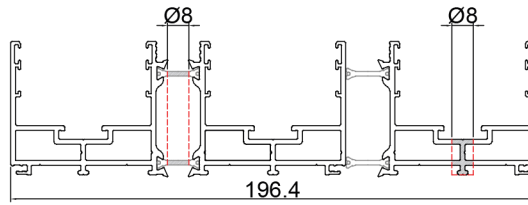
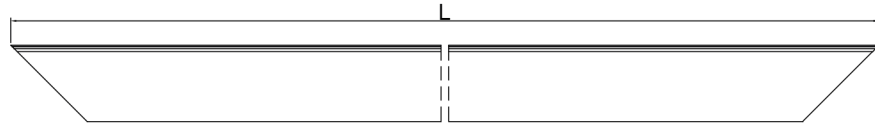

01

VERIFICATION OF ALL PLANES OF THE WAYS BEFORE THE INSTALLATION OF THE FIXED FRAMES.

correct ✓

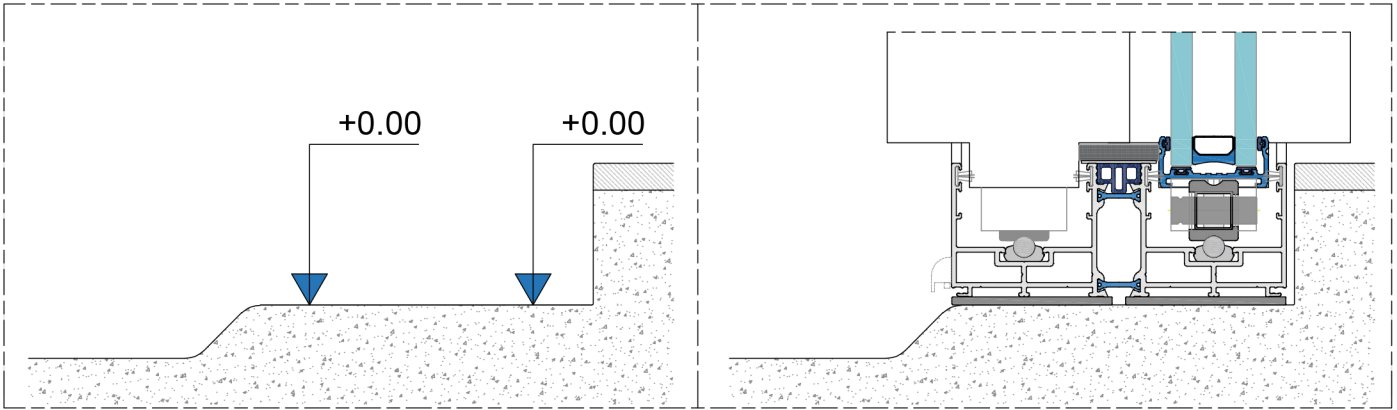

incorrect ✗

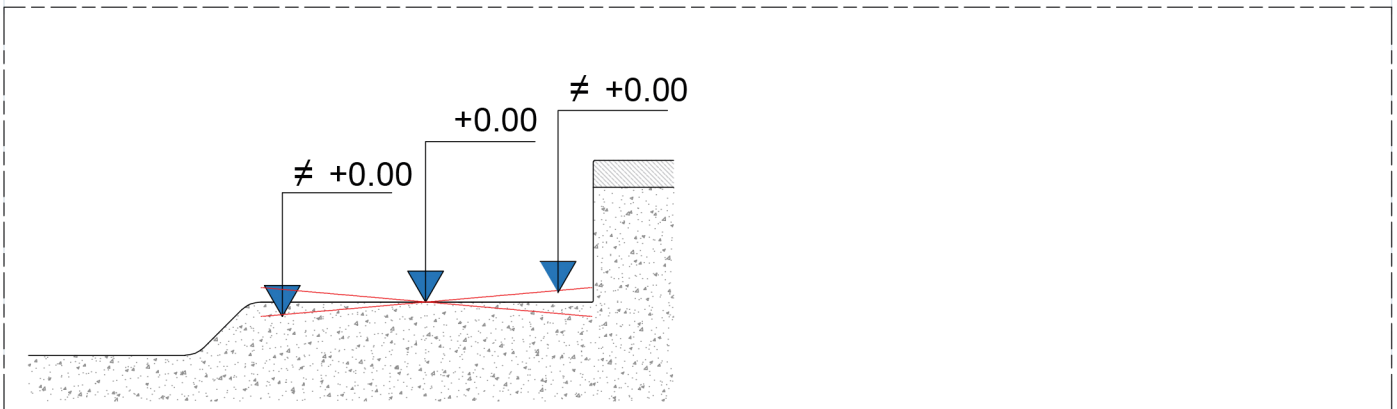

01

VERIFICATION OF ALL PLANES OF THE WAYS BEFORE THE INSTALLATION OF THE FIXED FRAMES.

correct ✓

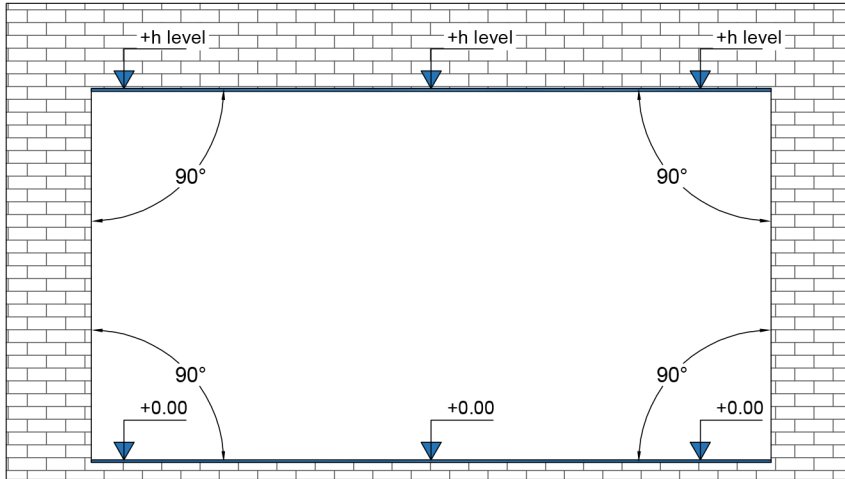

incorrect ✗

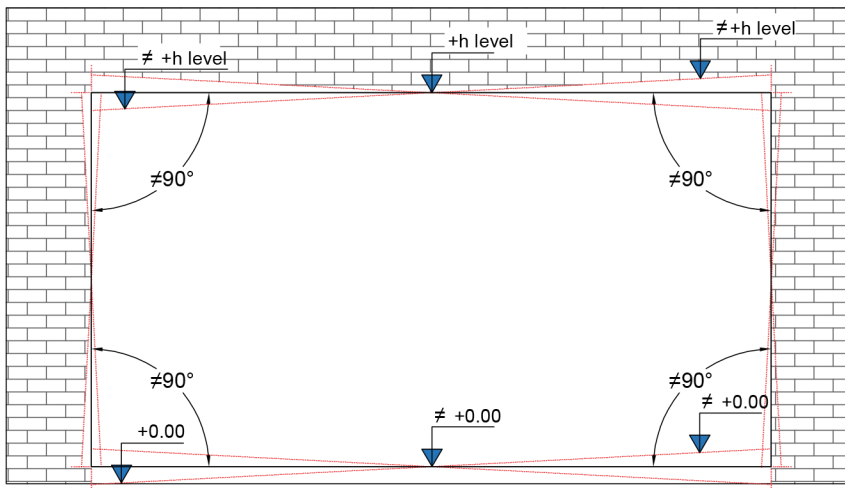

incorrect ✗

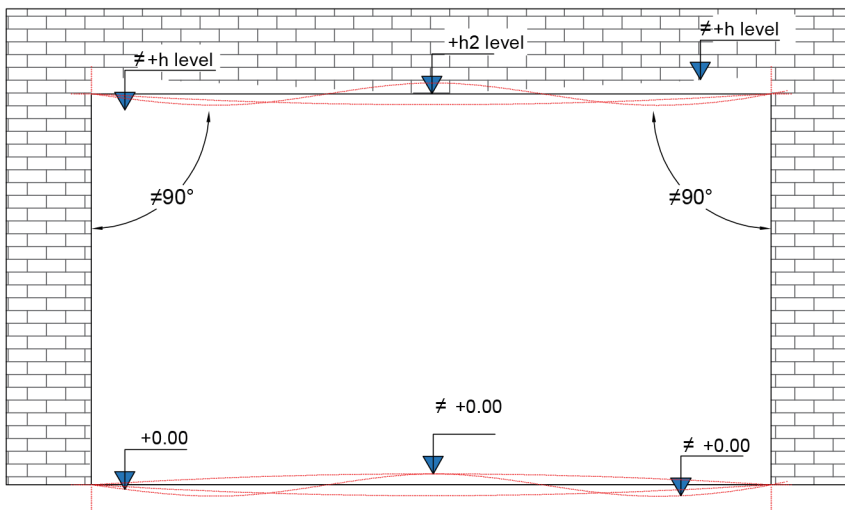

NOTE: NEVER CARRY OUT THE INSTALLATION OF A FIXED FRAME WITHOUT THE PLANIMETRIES OF WILL BE OK.

**02** INSTALATION AND FIXATION OF FIXED FRAMES.

- 2.1 The holes of the fixed frames will be made in the manufacture and according to the rules;
- 2.2 The installation of fixed frames should be very rigorous, especially in planimetry and leveling. Use as a support a good level (optical laser preferably);

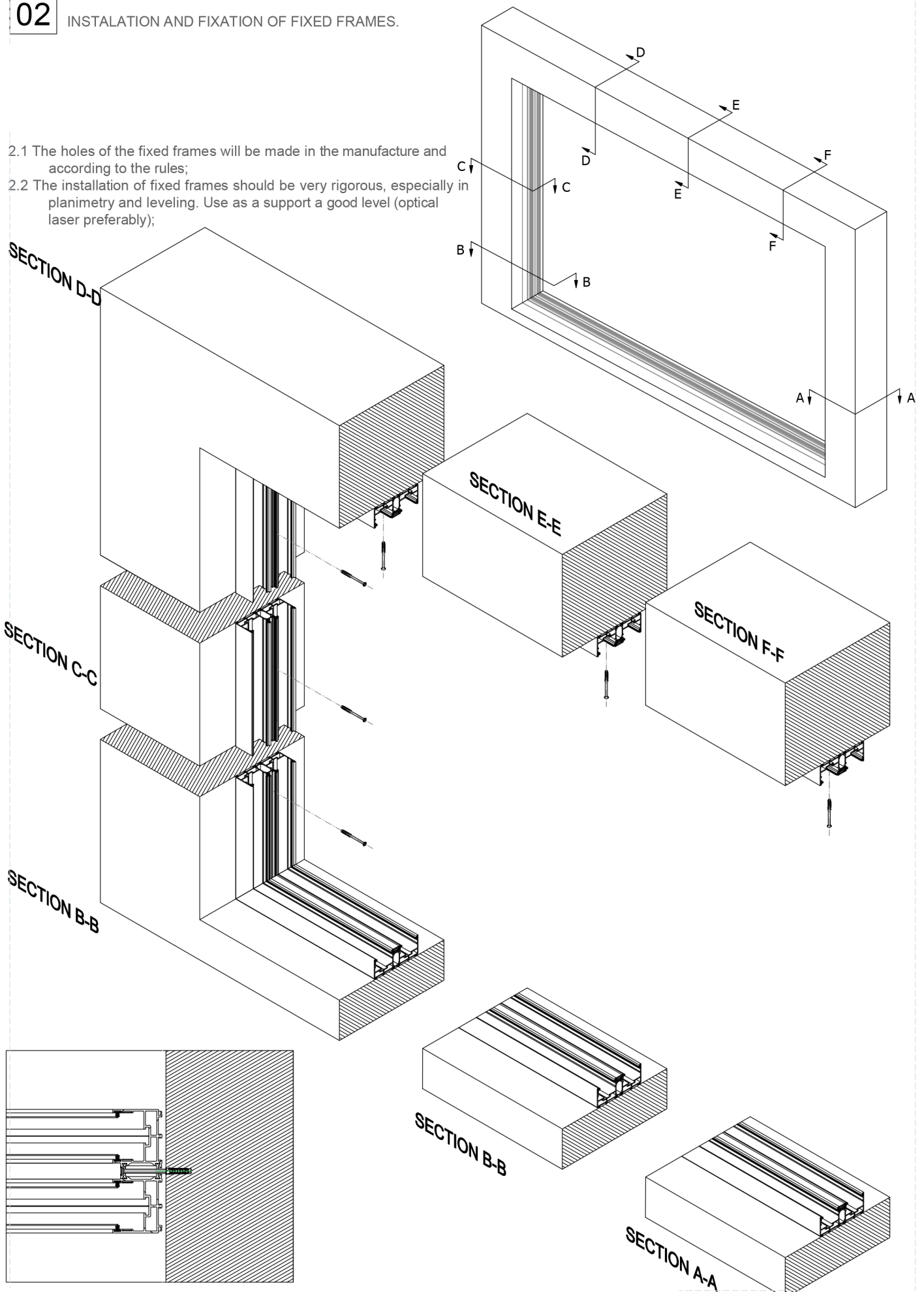



**03** APPLICATION OF GLASSES

3.1 Fit the glass to the lower rail;

3.2 Position the glass vertically so that the trolleys can be fitted;

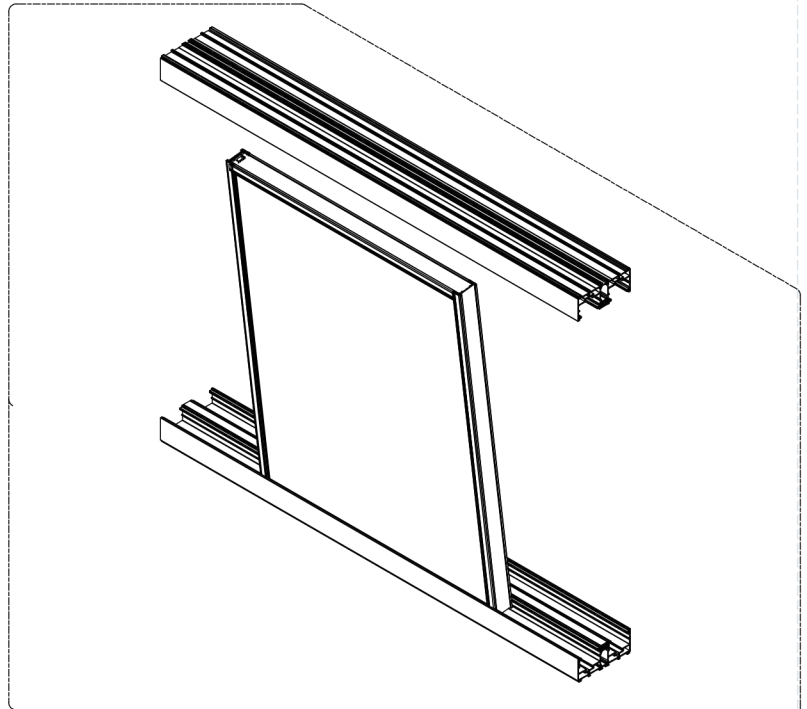
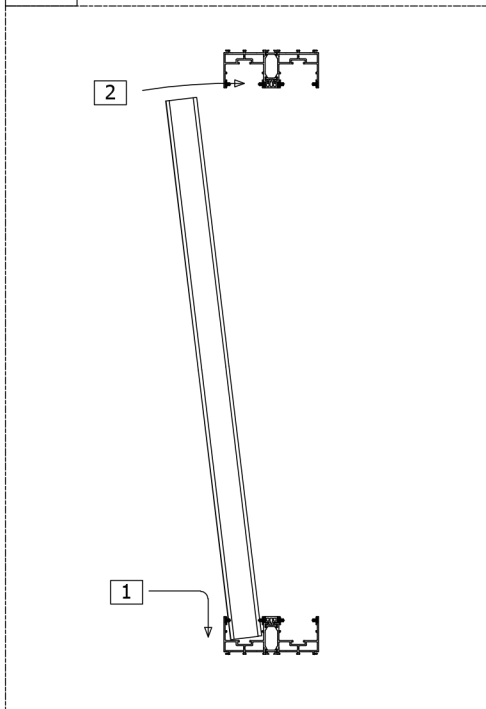
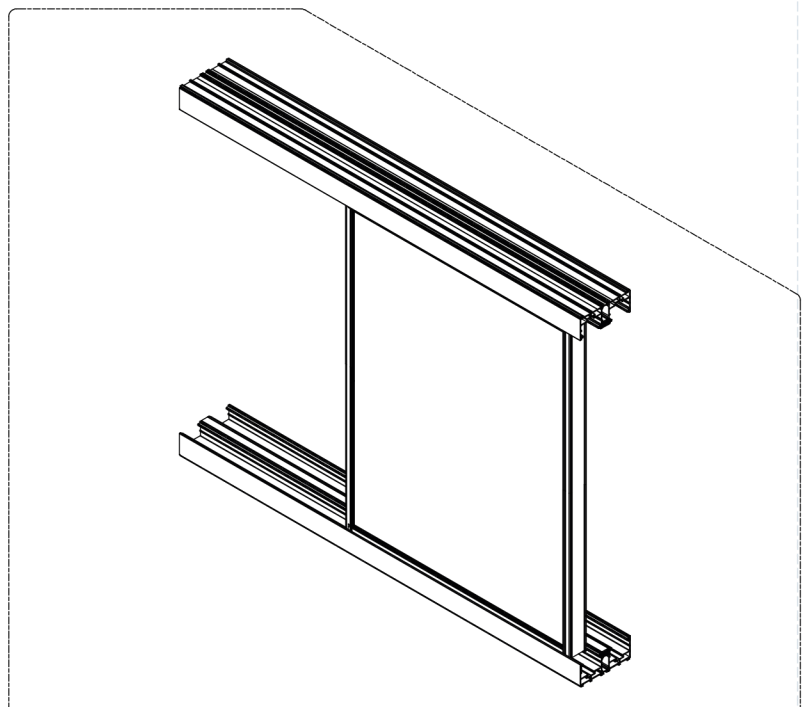
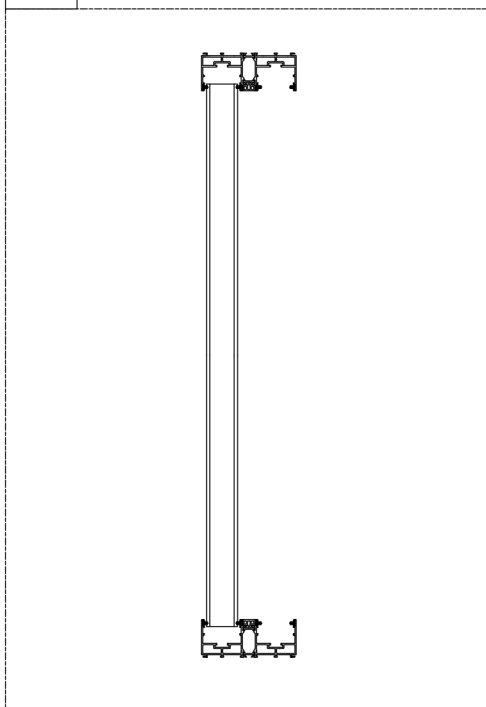
**3.1****3.2**

## 04

## APPLICATION OF ACCESSORIES

- 4.1 Raise the end 1 of the glass (side of the glass);
- 4.2 Attach the trolleys with the FE 111 side fastener to the profile channel / inf. of glass;
- 4.3 Raise the end 2 of the glass (central side of the sheet);
- 4.4 Attach the trolleys with the FE 011 center fixture to the profile channel / inf. of glass;
- 4.5 Attach and attach the FE-112 side fastener;
- 4.6 Attach the FE-011 center fastener;
- 4.7 Insert the side closure and to clip profile;
- 4.8 Attach and clip the center profile;

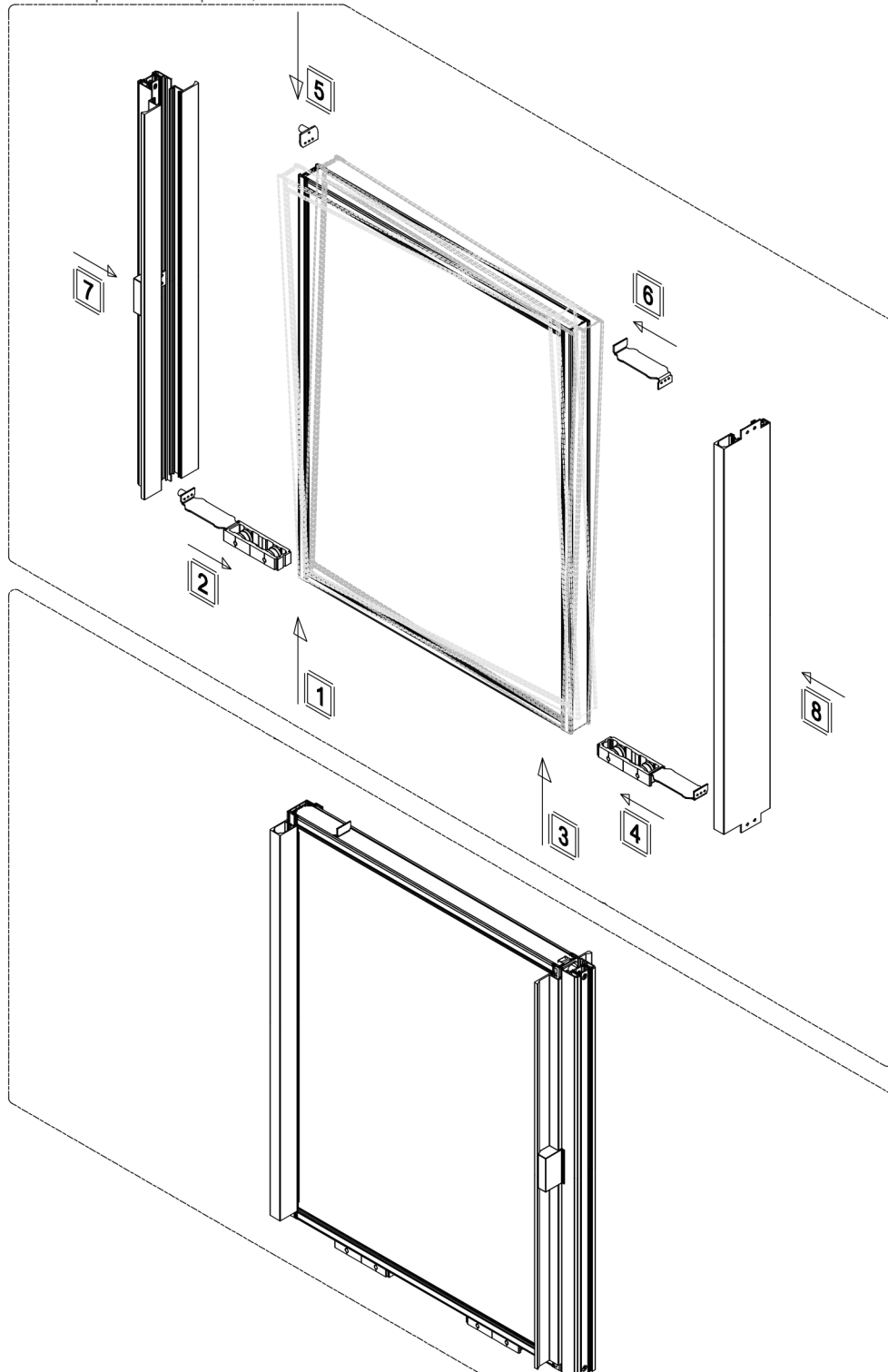

04

APPLICATION OF ACCESSORIES

DISMOUNTED

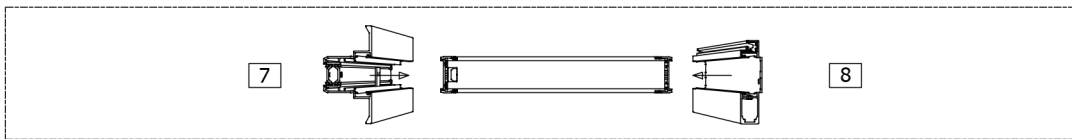
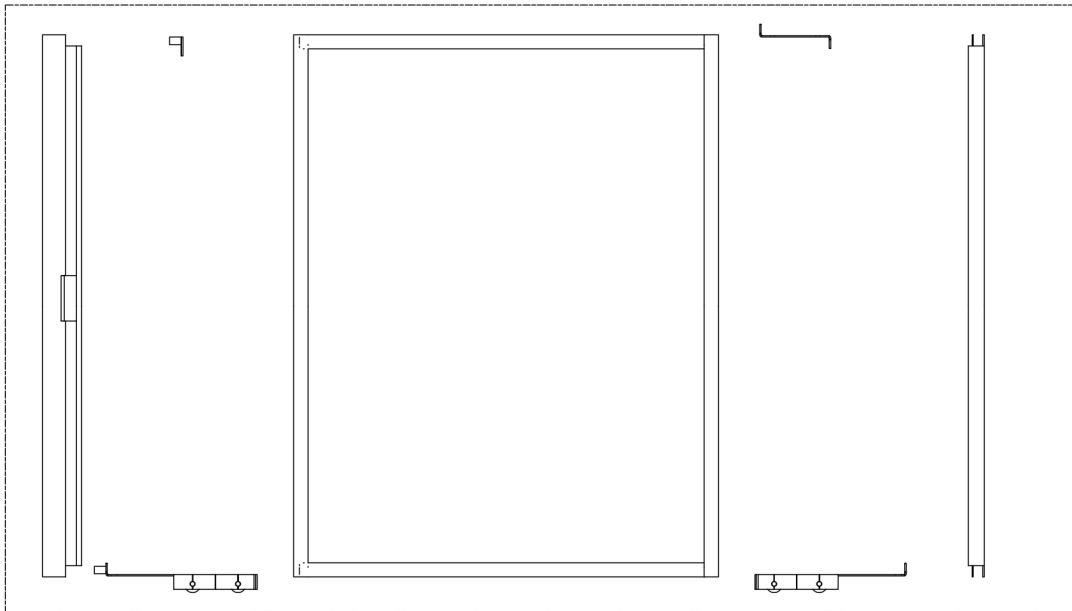

MOUNTED

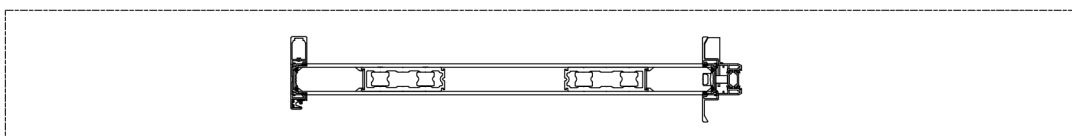
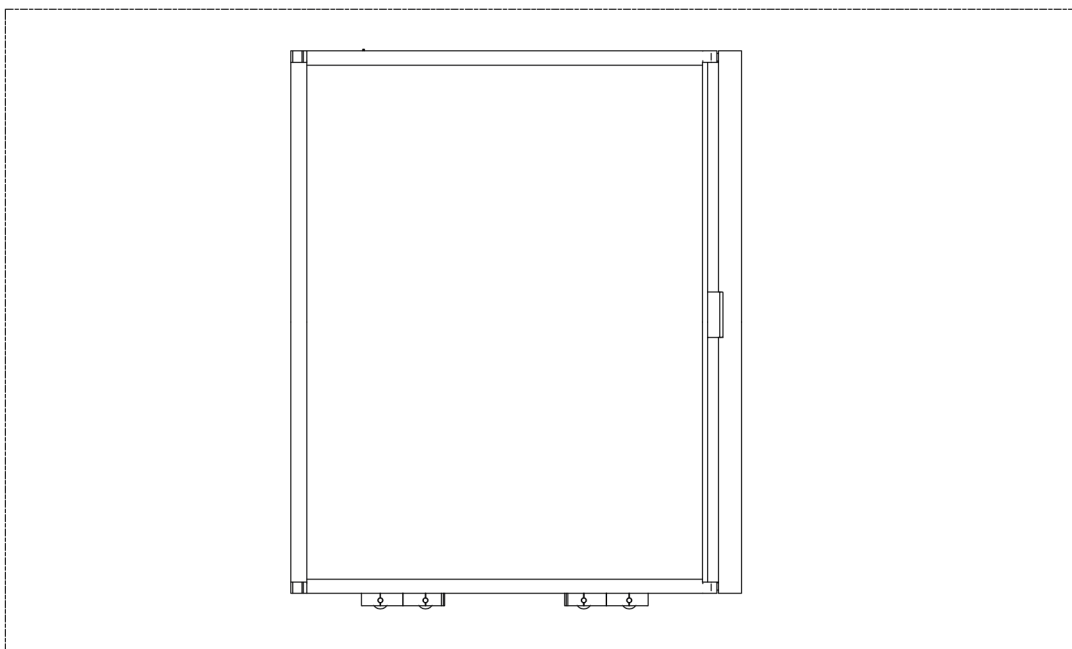

EXP-C(HR)

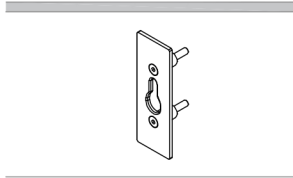

FE 301

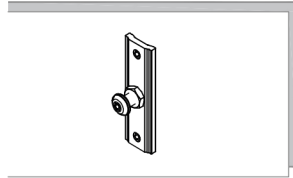

FE 05

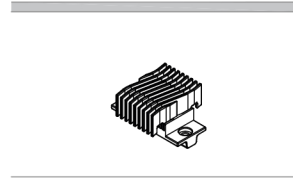

FE 093



FE 016

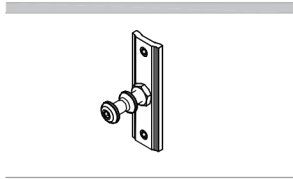

FE 06

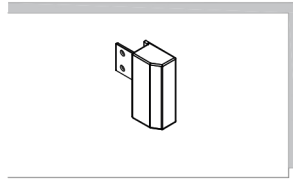

FE 009

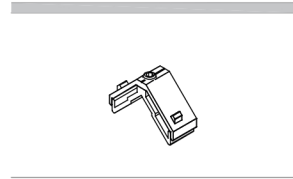

FE 315

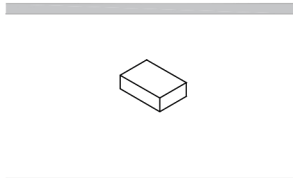

FE 013

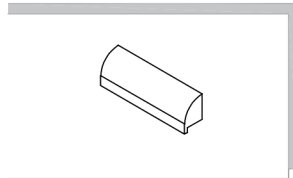

FE 014

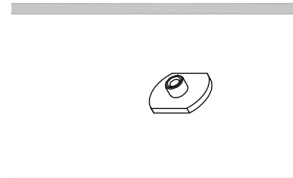

FE 021

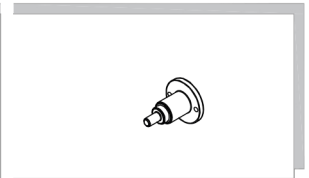

FE 026

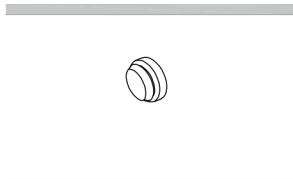

PL 010

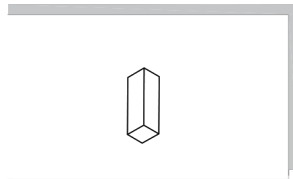

PL 040

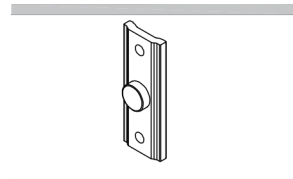

FE 028

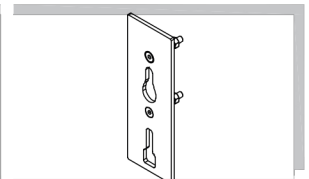

FE 327

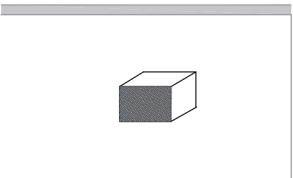

FE 060.1

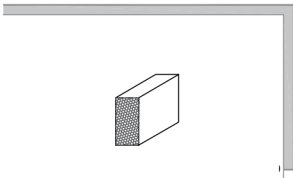

FE 060.2

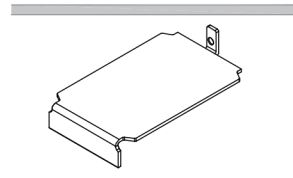

FE 341

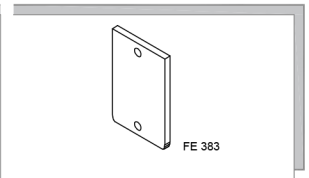

FE 383

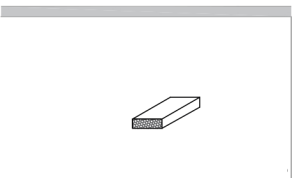

FE 302

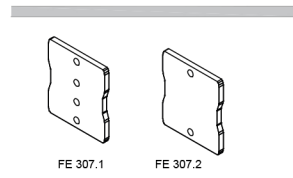
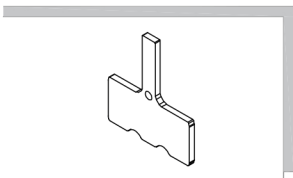

FE 307.1

FE 307.2

FE 307

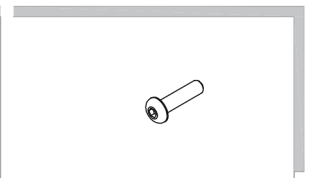

PF 204

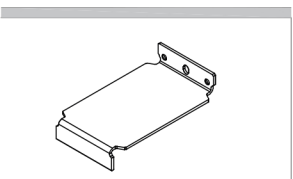

FE 311

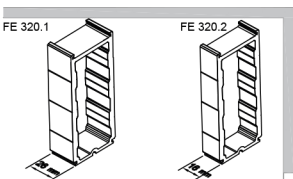

FE 320.1

FE 320.2

FE 320.1  
FE 320.2

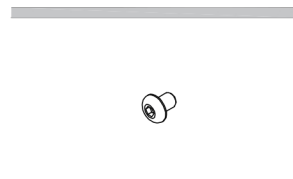

PF 216

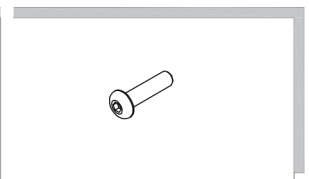

PF 217

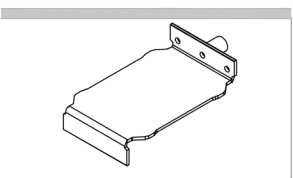

FE 321

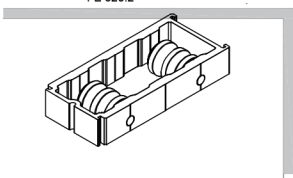

FE 331

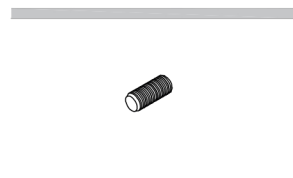

PF 236

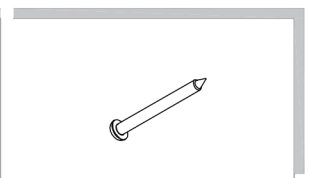

PF 246



EXP-C (HR) ACCESSORIES - WINDOW 2 MOBIL LEAFS - FIX FRAME

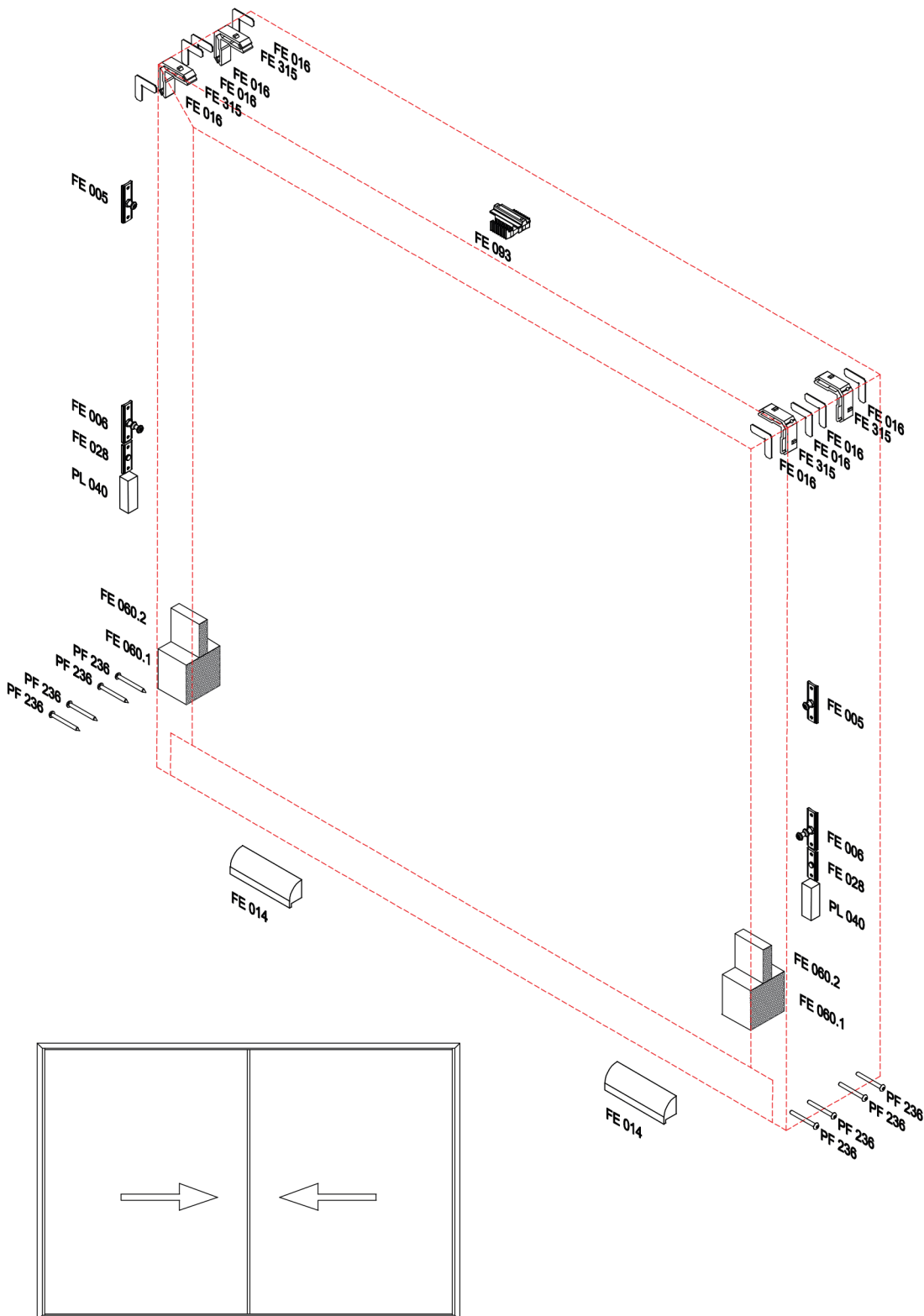

EXP-C (HR) ACCESSORIES - WINDOW 2 LEAFS - MOBIL LEAFS

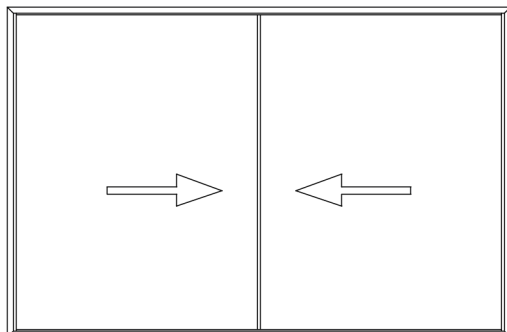
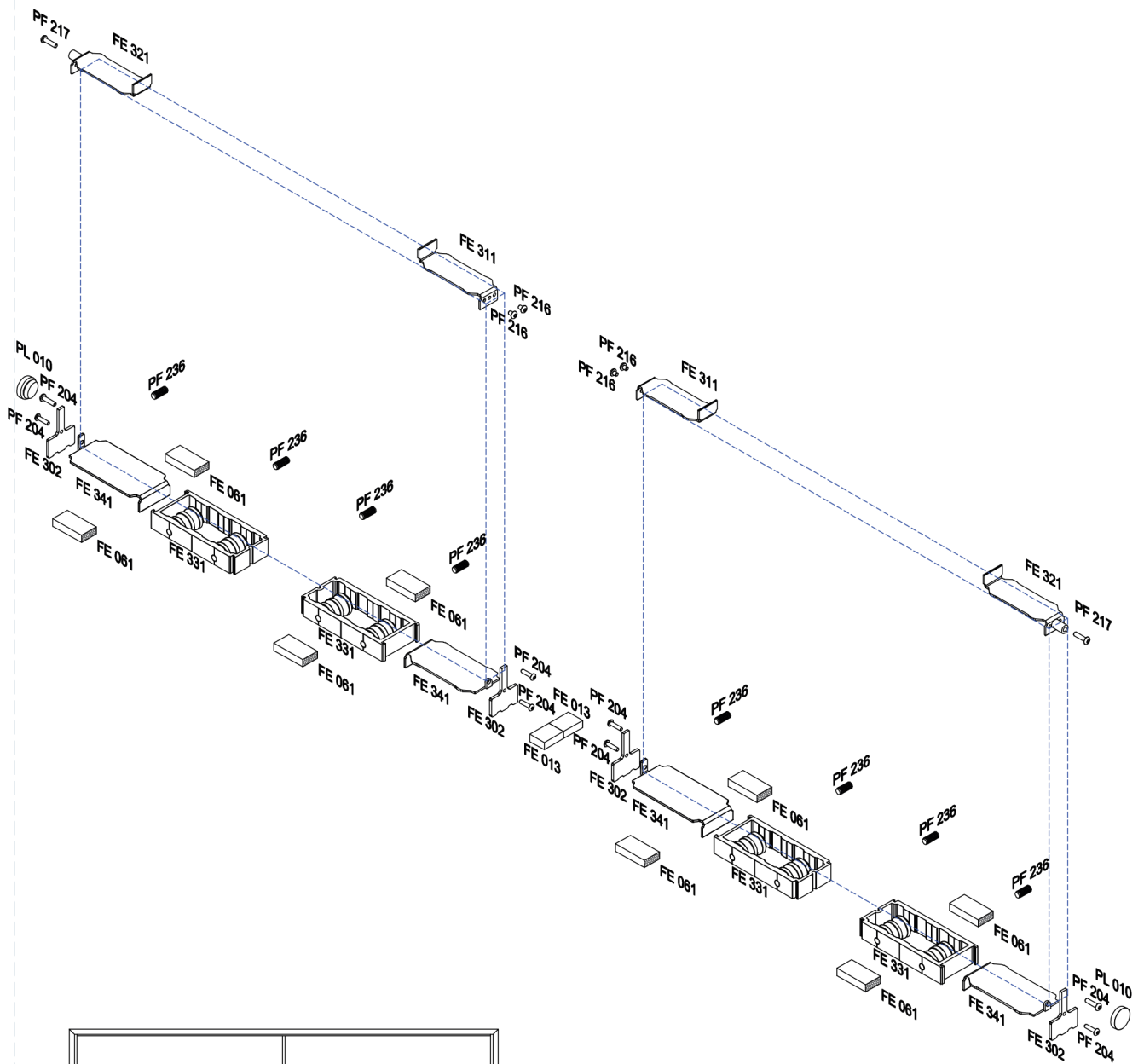

EXP-C (HR) ACCESSORIES - WINDOW 2 MOBIL LEAFS - 1M+1F

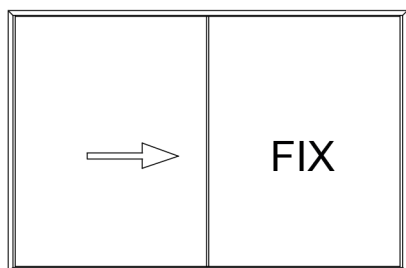
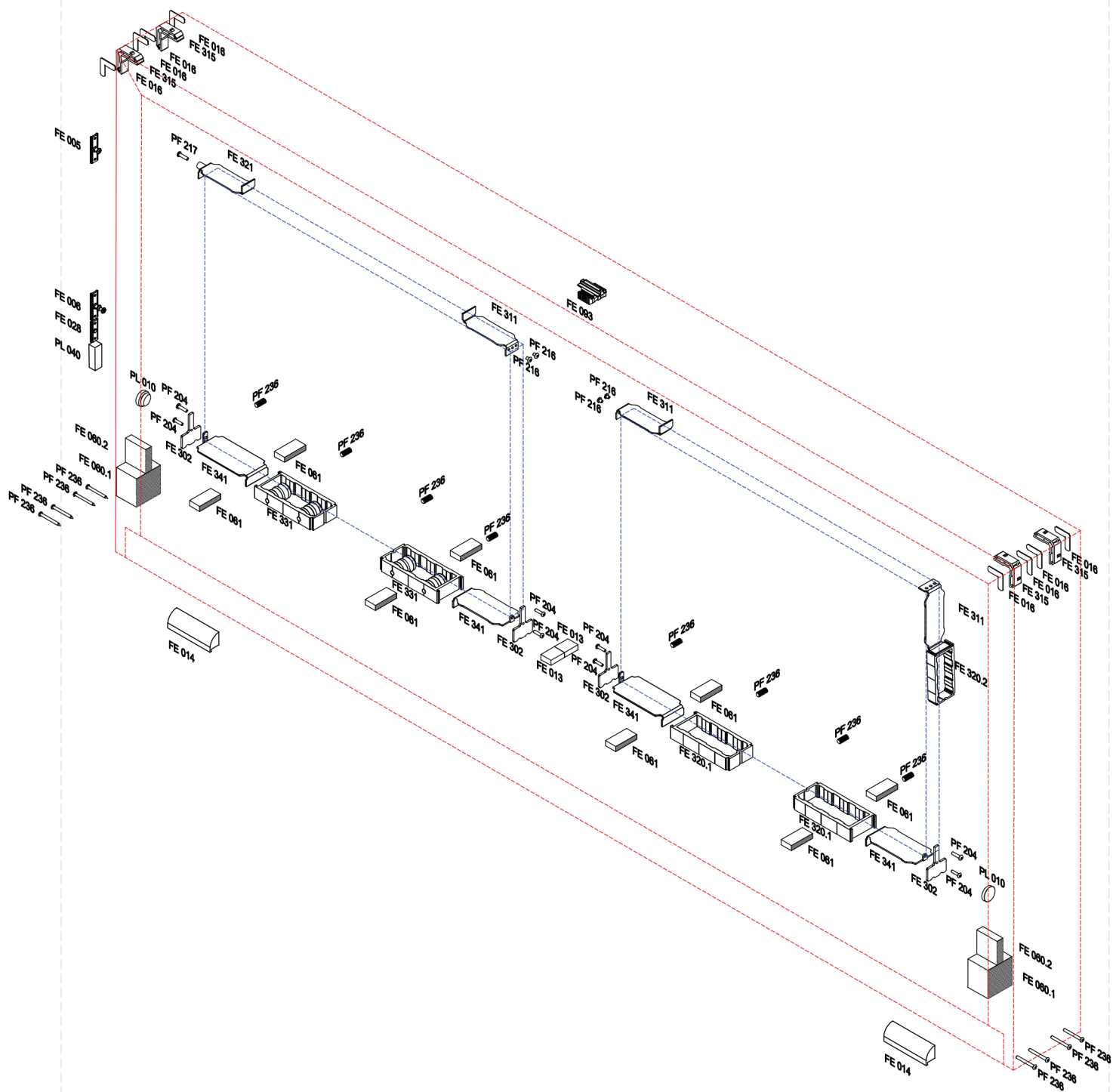



EXP-C (HR) ACCESSORIES - WINDOW 2 MOBIL LEAFS - FIX FRAME

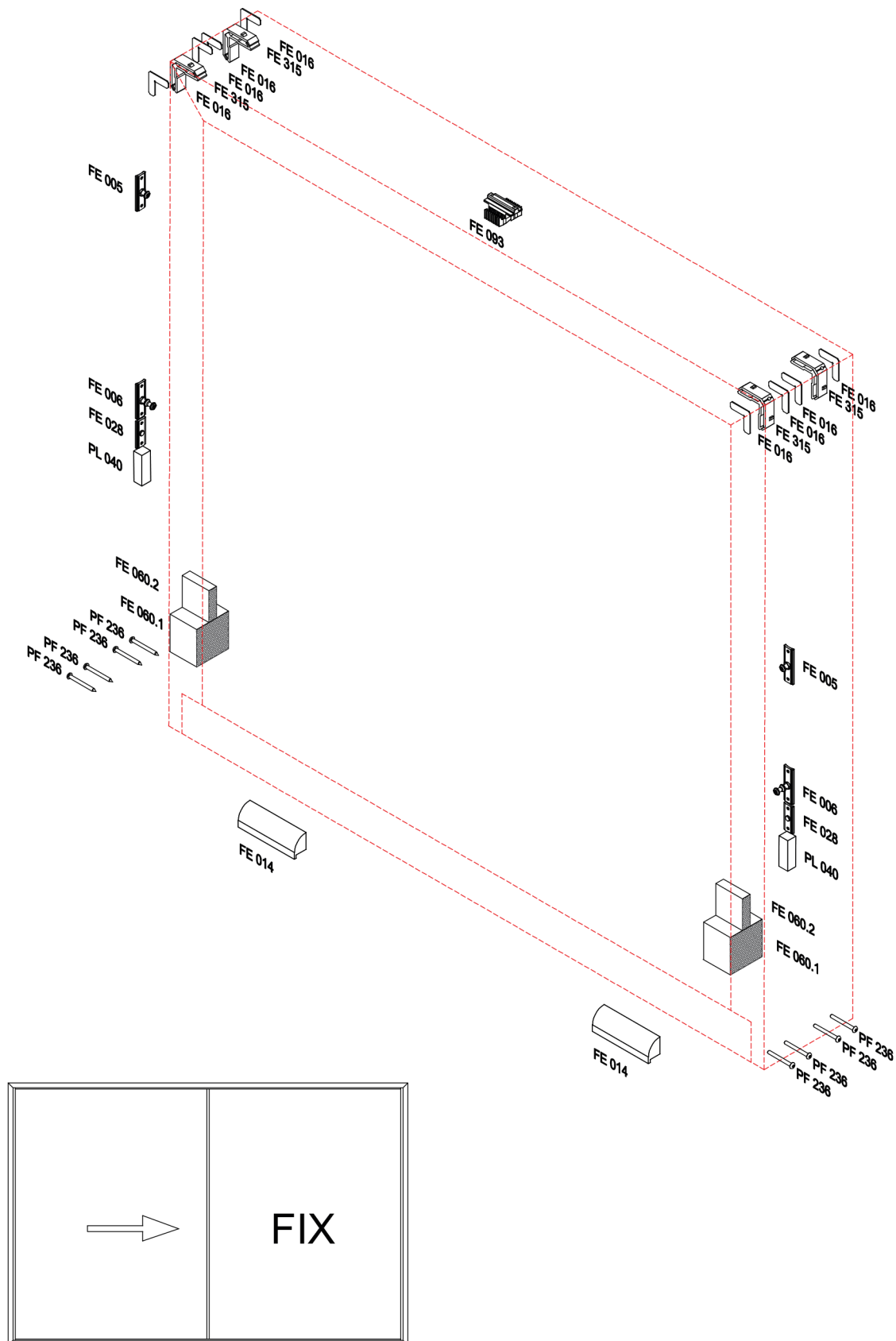

EXP-C (HR) ACCESSORIES - WINDOW 2 LEAFS - 1 MOBIL LEAF + 1 FIX

